



TrekkerTM
PORTABLE SPACE HEATER

Installation and Operating Manual



CERTIFIED TO CSA AND UL STANDARDS

Table of Contents

Table of Contents	ii
Overview.....	1
1. Safe Operation	1
2. DOs and DO NOTs	2
3. Components	4
4. Installation	7
5. Operation	13
6. Oil Control Valve.....	15
7. Maintenance	16
8. Trouble Shooting	18

READ THESE INSTRUCTIONS AND SAVE THEM FOR FUTURE REFERENCE

Overview

Make sure you read and understand this manual before installing and operating your **TREKKER**. If you have any questions, or require any explanation, please contact your authorized ITR dealer.

Thank you for purchasing International Thermal Research's (ITR) **Trekker** space heater.

The **Trekker** Heater is a vaporizing pot burner type space heater with a simple, effective design that produces radiant and convection heat through the efficient combustion of liquid fuel. With regular maintenance and proper operation your heater will function satisfactorily for many years.

The **Trekker** heat output ranges from 4,000 to 12,000 BTU's, sufficient to heat garages, small workshops, cabins, ice fishing shacks, or tents. The heater may also be used for supplemental heating in larger spaces.

Table 1: General Information

Nominal heat output	Oil Consumption		Chimney draught		Weight	Flue diameter
	Min	max	min	Max		
12,000 BTU/Hr	0.06 US Gal/h	0.12 US Gal/h	.03" W.C.	.045" W.C.	20 Lbs	Ø3 inches
3,5 kW	0,24 Litre/h	0,48 Litre/h	7,5 Pa	11.25 Pa	9 kg	76,2 mm

1. Safe Operation

Proper installation, operation and maintenance procedures laid out in this manual, as well as local government requirements, must be followed to insure the safe operation of your **Trekker**. CSA standard B139, Installation Code for Oil Burning Equipment, UL896, or NFPA#31 are standards that apply to this equipment.

Make sure you read, and understand these instructions and save them for future reference. If you have any questions or don't understand anything in this manual, contact your authorized ITR dealer.

2. DOs and DO NOTs

DO's

DO determine what heater and exhaust stack installation regulations apply to your local area. All heaters and exhaust stacks must be installed according to the standards mandated by the local, state/provincial and federal government authorities. These standards deal with various matters including heater and flue setbacks and fuel storage.

DO mount the heater securely to a non-combustible floor. If a heater is not solidly secured and is knocked over, a serious fire hazard could result. Also, ensure that the heater is level before it is secured down.

DO use clean #1 and #2 diesel fuel only in your heater. If you burn any other fuel or burn contaminated diesel, you will void your warranty, cause damage to the fuel control valve and may cause a fire or even an explosion.

DO inspect the entire fuel line to the heater and any connection points for fuel leaks before firing the heater. The fuel line and connection points must be leak free before the heater is operated.

DO inspect the space below the burner to make sure there are no blockages and, if there is any dust or dirt present, it should be removed before operating the heater. The heater requires oxygen for combustion purposes.

DO inspect the exhaust flue (stove pipe and elbows) to make sure it is secure to the heater, not blocked, and is leak free.

DO check the draft on the initial setup of the heater by using a draft meter and ensure the heater is operating under the recommended draft setting. Because of the unique vaporizing design of the heater, the correct draft is essential for the heater to operate in a satisfactory manner. If a draft meter is not present, the draft conditions MUST be estimated. See the details in the manual for estimating the draft conditions.

DO make sure that you have a window or door opened a bit to allow fresh air to enter the same area where the heater is operating.

DO install carbon monoxide and smoke detectors in the same room as the heater for safety purposes.

DO NOT'S

DO NOT install the heater or flue unless installation conforms with the regulations governing your location.

DO NOT use any fuel other than clean #1 or 2 diesel.

DO NOT operate the heater without initially checking the position of the S-tube. During shipping, the S-tube may become dislodged from the center fuel up tube. View the position of the S-tube through the glass viewing lid on the top of the heater. If the S-tube is dislodged, remove the top lid of the heater and reposition the S-tube over the center fuel up-tube.

DO NOT operate the heater without both a complete exhaust stack in place and correct draft conditions. Excessive carbon will form in the fuel up-tube and must be cleaned out for the heater to function correctly.

DO NOT operate the heater in air tight conditions. The heater requires air to operate and its use will lead to oxygen deprivation in the air tight space. An outside source of air must be provided to replace the oxygen that is used up by the operation of the heater.

DO NOT operate the heater if you smell smoke or exhaust fumes during its operation. Shut the heater down immediately and examine the stove pipe for leaks or poor fit. Repair as required so that all exhaust fumes are vented outside.

DO NOT attempt to relight the heater when it is hot. If the unit is shut down for any reason, wait until the heater cools down to room temperature before re-firing.

DO NOT leave the heater running unattended. All heaters, regardless of the type or make, can malfunction and all manufacturers recommend that heaters are not left running unattended. The *Expedition* is mechanically capable of operating unattended, but if there is a malfunction ITR accepts no responsibility or liability for any damage caused, regardless of the type or extent of the damage. **THIS PARAGRAPH CONTAINS LANGUAGE THAT LIMITS THE MANUFACTURER'S LIABILITY**

The Canadian Standards Association (CSA) has some additional consumer tips for space heaters. Some of those tips are:

DO NOT hang wet clothing above the heater to dry it. The clothing can catch fire as it dries

DO supervise young children when in the same room as the heater

DO NOT keep gasoline, solvents or other flammable or vapourizing liquids in the same room as the heater.

More tips can be found on http://www.csa.ca/consumers/consumer_tips/.

Components

A.) *Trekker* major external components (see Figure)

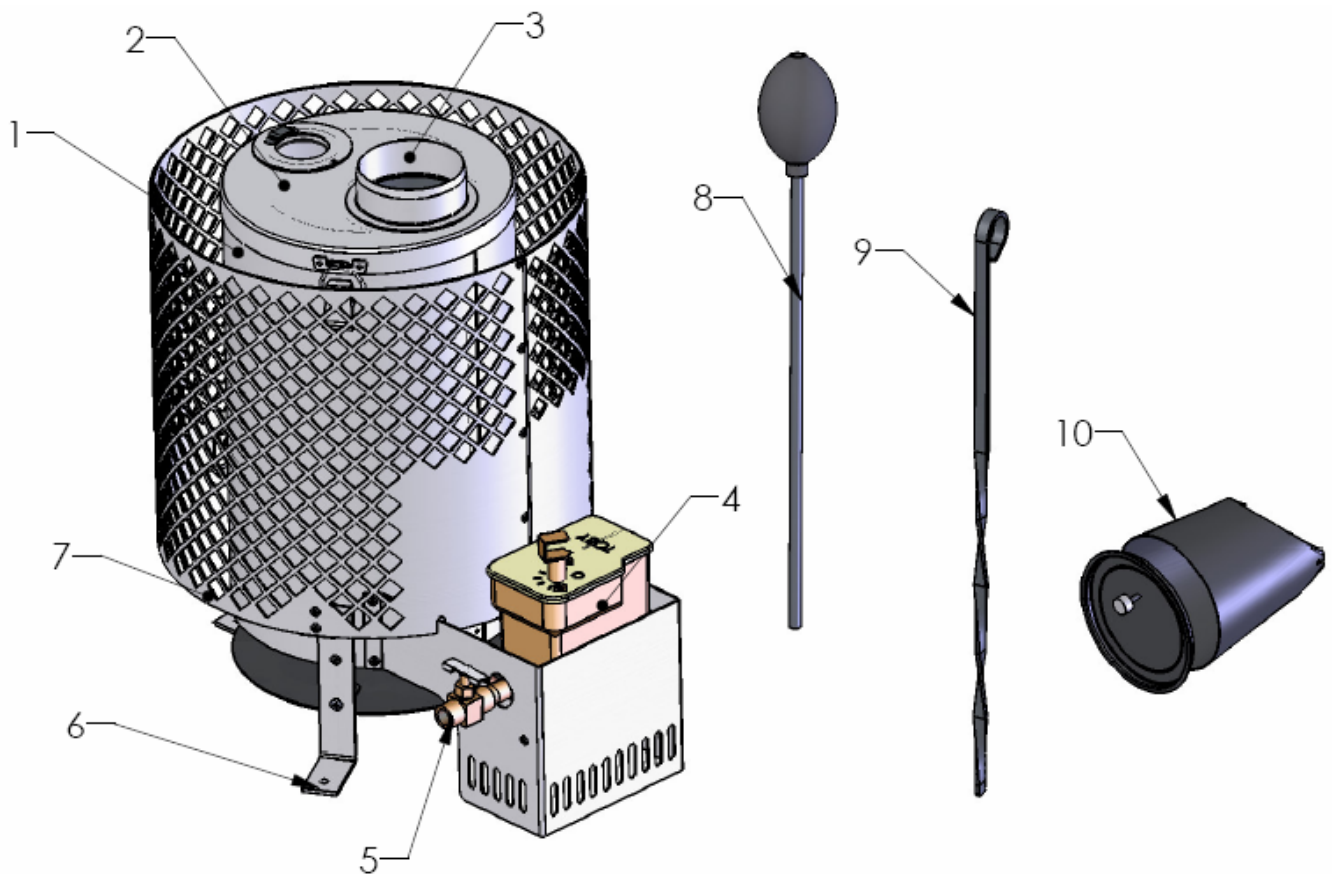

Heater Shell (1) – The heater shell assembly is the area of the heater containing the burner shell.

Top Lid (2) – Contains a sight glass to observe the flame.

Flue Collar (3) – To attach a Ø3" Flue Stack

Toby Oil Control Valve (4) – Located on the side of the heater and controls the amount of fuel supplied to the burner. Turning the control knob will allow more or less fuel to enter the burner. See sections 5 & 6.

Fuel shut off valve (5) - Opens or closes the flow from the fuel tank to the Oil Control Valve. Fuel line connection: 1/4" NPT female threaded fitting

Drain Valve (5a) – To fill up the primer cup or to drain fuel from the control valve.

Legs (6) – To level the heater and mount it to the floor

Heat shield (7) – Perforated shield surrounding the *Trekker* Heater prevents accidental contact with the hot heater shell during heater operation.

Primer Bulb/ Fuel dispenser (8) – To put fuel in the bottom of the burner base before lighting the heater.

Reamer Tool (9) – To clean the Up-Tube from soot and carbon built up.

Draft Regulator (10) – To maintain a stable draft.

B.) *Trekker* major internal components (See Figure)

Up-Tube (20) – Receives fuel from the oil control valve and permits fuel vapours to flow into the S-Tube (25) during operation.

High Fire Ring (21) – Clean below High Fire Ring periodically, remove any build up of soot or hard carbon deposits and vacuum.

Burner Shell (22) – Area of the heater where combustion occurs. The perforated Burner Shell contains an up-tube (20) welded to the base of the shell and a removable, capped S-Tube (25) which sits over the welded up-tube. The Burner Shell is permanently mounted inside the Burner Shell Assembly and can be accessed by removing the Burner Lid.

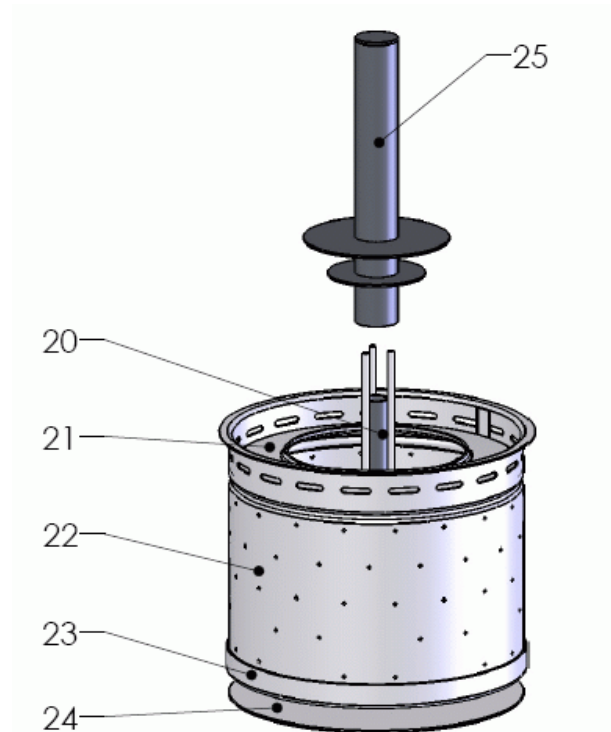

Burner Base (23) – Bottom of Burner Shell (22). Periodic cleaning of soot and carbon build up required.

Heat Shield (24) – Heat insulator to keep heat inside the Burner Shell and away from the bottom of the *Trekker* Unit.

S-Tube (25) – The large capped tube in the center of the perforated Burner Shell is the S-Tube. During shipping, the S-tube may become dislodged from the center fuel up tube (20). If the S-tube has become dislodged, which can be seen through

the glass on the lid, the top of the heater must be removed to position the S-tube over the fuel up-tube. **DO NOT** operate the heater without initially checking the position of the S-tube.

During operation, fuel flows through the Up-Tube (20) where its level is gravity maintained with the Toby Control Valve (4). Fuel vaporizes due to combustion heat and is expelled from the up-tube, down through the S-tube and into the perforated burner shell where it ignites.

Note: If any parts appeared damaged, do not operate the heater. Contact your authorized **Trekker** Dealer.

When unpacking the heater, remove any packing material from the side of the burner canister and around the air intake area.

C.) **Trekker Exhaust kit (Optional) for tent or portable building**

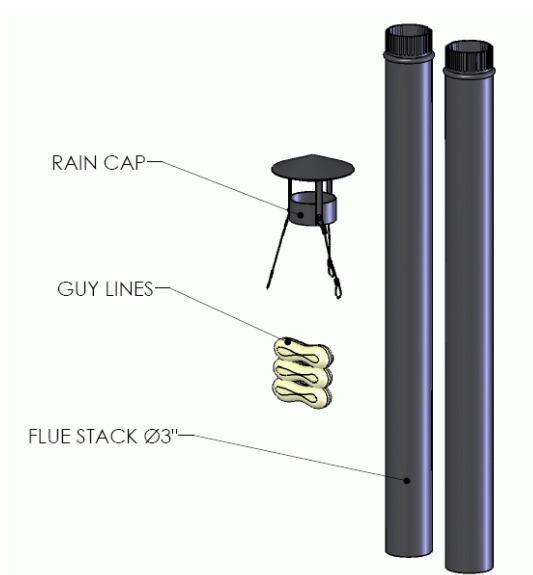

The exhaust kit for the Trekker comes with eight pieces of Ø3 inch diameter x 18 inch length flue stack, a rain cap and three guy lines.

D.) **Trekker Fuel Line kit (Optional) for tent or portable building**

The Fuel line kit comes with an inline fuel filter, 10 feet of hose and a fitting to connect to the oil control valve.

4. Installation

A.) Location and Mounting

The **Trekker** heater may be placed on a flat level surface made of material that can resist heat. Hardwood, plywood, concrete, etc. are acceptable. The **Trekker** should not be mounted directly on a carpeted floor. Use a solid platform or rigid heat resistant material between the carpet and the heater.

Ideally a large open space would best suit the heater. The surfaces of the heater and the flue stack will be generating heat and should be taken into consideration when mounting the heater.

The minimum standard clearance between the heater and any building construction other than the floor is 16 inches (40 cm). The minimum standard clearance between the exhaust vent pipe and any building construction is 16 inches (40 cm).

An unlevelled heater will not operate properly and could be dangerous. Adjust the heater perfectly level in all directions before mounting.

The heater should be securely mounted to the floor. The legs contain a 1/4" hole for directly fastening the heater to the floor.

B.) Exhaust Flue Stack (General application)

OIL BURNING APPLIANCES MUST BE CONNECTED TO FLUES HAVING SUFFICIENT DRAFT AT ALL TIMES TO ASSURE SAFE AND PROPER OPERATION OF THE BURNER.

All heaters must be installed according to the installation rules mandated by local, state/provincial, and federal government authorities. These regulations deal with various matters including heater and flue set backs and fuel storage. **DO** determine what regulations apply in your local area. **DO NOT** install the heater or the exhaust flue stack unless the installation conforms with the regulations governing your location.

The **Trekker** does not come with an exhaust flue stack. Blue stove pipe or All-Fuel "L" type vent capable of continuous use for flue gas temperatures up to 1000°F may be used. Always use flue stacks that are at least the same diameter as the flue collar on the heater. Appropriate parts for the appropriate flue stack must be purchased at your local heating and ventilation companies. As all installations differ, it is necessary that you follow all local, state/provincial, and federal guidelines in selecting the type, method, and location of the exhaust flue stack for your particular situation.

Before the hooking up of the *Trekker* to a chimney, check to make sure the chimney is in good condition and that the flue pipe will allow sufficient draft. A maximum horizontal length of 3' is allowed. Make sure to have a 1/4" slope per foot minimum. Do not use more than two 90° elbows for connecting stove to chimney.

DO NOT connect horizontal exhaust stacks directly off the heater. The heater will not operate correctly and will not stay lit.

The minimum flue stack height for an angled roof with top opening exit and a vertical only flue stack is 8 feet (2.44 m). For a vertical sidewall exit with a horizontal run of three feet, the minimum vertical stack height is 12 feet (3.6 m).

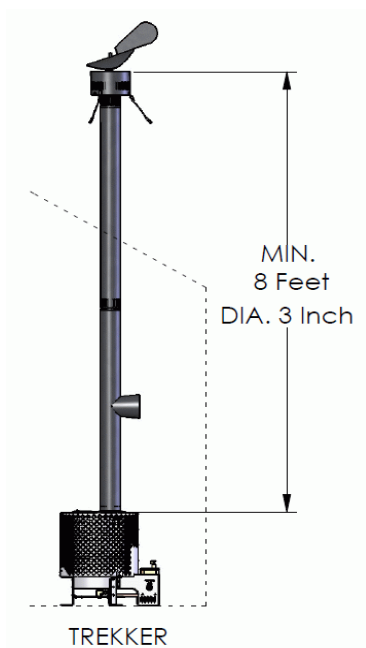

SAMPLE EXHAUSTS: ROOF EXIT
AND SIDEWALL EXIT

Exhaust location: angled
roof (standard
configuration)

Install the included draft regulator which is necessary in order to maintain stable draft in certain conditions.

DRAFT CONDITIONS All heaters require the proper draft.

If a draft meter is available, set the heater to the recommended water column reading. The recommended draft for the *Trekker* is between .040-.060 inches water column. This is measured 18" (45cm) up the stack, before the draft regulator, and with the final exhaust stack configuration in place. Follow the manufacturer's instruction for the installation, location, and adjusting of the draft regulator.

If a draft meter is not available, estimate the draft (see below).

TO ESTIMATE THE DRAFT Set up the heater with the final exhaust stack configuration in place. Start the heater, and set the heater to **operate at the #1 setting (position indicated by the first raised notch on the fuel control valve) only**. Do not operate the heater at any other setting or the flame will be distorted. After 10 minutes of operation, view the burner flame through the glass lid on the top of the heater. Look for the level of the tips of the flame relative to the top of the S-tube. The correct draft is approximated by the flame tips at the same height as the top of the S-tube.

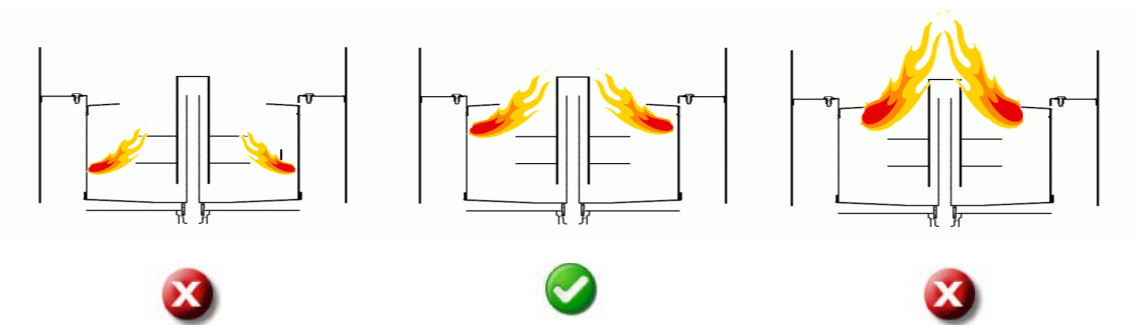

HIGH DRAFT:

The tips of the flame are at a level lower than the top of the "S" tube.

CORRECT DRAFT:

The tips of the flame are at the same level as the top of the "S" tube

LOW DRAFT:

The tips of the flame are at a level higher than the top of the "S" tube.

TO ADJUST THE DRAFT In general, the draft can be increased by increasing the existing vertical stack height. Decrease the draft by decreasing the existing vertical stack height. If a draft regulator is present, adjust the settings on the draft regulator until the desired draft setting is reached. Follow the manufacturer's instructions on use of the regulator.

The *Trekker* emits very little carbon and soot into the flue system. However it may be convenient to design your flue system so it can be brushed clean if necessary.

For safe operation, it is highly recommended that the installed exhaust system be inspected by a qualified professional to ensure the suitability of the type and method of the installation.

During operation, the heater produces harmful carbon monoxide (CO) and other gases. To prevent CO poisoning, ensure the exhaust stack sections fit together

snugly and that the exhaust gases are properly vented through the roof or sidewall.

The chimney flue should extend at least 2 ft (0,6m) above the highest roof surface or structure within 10 ft (3,0m) horizontally of the chimney to prevent down drafts.

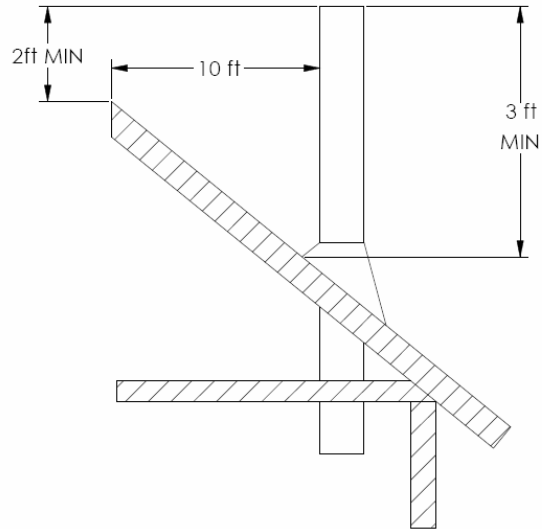

The **Trekker** emits very little carbon and soot into the flue system. However it may be convenient to design your flue system so it can be brushed clean if necessary.

For safe operation, it is highly recommended that the installed exhaust system be inspected by a qualified professional to ensure the suitability of the type and method of the installation.

C.) Exhaust Kit for Tent or Portable building **ONLY** (Optional)

The trekker can be installed in tents or portable buildings (both heat and/or fire resistant) using the optional exhaust kit. The exhaust kit is designed for exhausting through the roof of the tent or portable building. The following are general guidelines for venting through this type of structure.

Some tents and portable buildings have a stovejack or protected opening in the roof for the passage of an exhaust flue stack. This opening and the surrounding area is protected from damage by heat by either insulated material or heat radiation shields. Only structures with these devices installed should be used. The optional exhaust kit is supplied with two, three foot sections of 3 inch diameter, single wall flue stacks and a rain cap. When assembled, the exhaust stack is inserted into the opening and the rain cap is installed and secured on top of the last section of stack. Tie one end of a guy line through the loop on one of the three wire ropes located on the rain cap. Use an overhand loop to secure the wire. Lower the assembled stack with the attached rain cap and secure it onto the flue

stack adapter on top of the heater. Position the stack vertically and secure it in place by attaching each of the three guy lines to the ground or building.

Always place the **Trekker** a safe distance from the tent or portable building wall on a certified fireproof mat or bricks. Swivel the legs outwards for a stability.

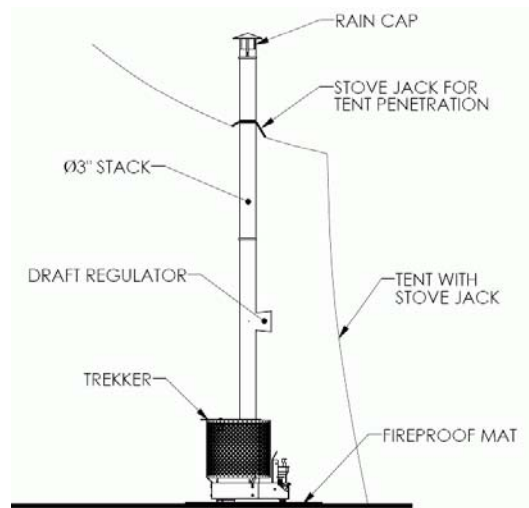

Overhand Loop

Note:

- The exhaust system must develop the recommended draft.
- When going through combustible material, all local codes for insulated stacks, protective shield clearances, etc. must be met.

During operation, the heater produces harmful carbon monoxide (CO) and other gases. To prevent CO poisoning, ensure the exhaust stack sections fit together snugly and that the exhaust gases are properly vented through the roof of the structure.

D.) Venting and Air Supply

The heater consumes about 4000 ft³ of air per 1 US gallon of oil. This air enters the heater through the air inlets and exits the chimney as combustion gas.

The **Trekker** should be installed in a well ventilated area that allows the entrance of outside fresh air.

E.) Connecting to Oil Tank

The external oil tank is to be installed in accordance with the manufacturer's instructions and the Standard to which the tank has been manufactured.

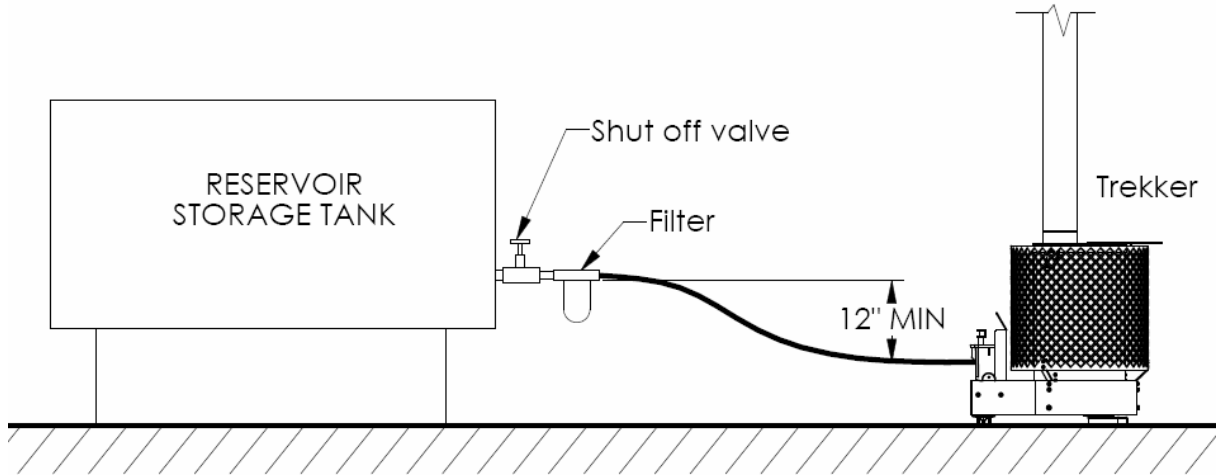

Make sure that the tank outlet is 12 inches (305 mm) higher than the inlet of the oil control valve. (Gravity fed). A good quality filter should be placed at the tank to ensure a clean supply of oil to your heater.

The fuel line must be clear of any air prior to operating the heater. A fuel line kit or a solid fuel line both must be cleared of air once the fuel line is attached to the heater (shown below)

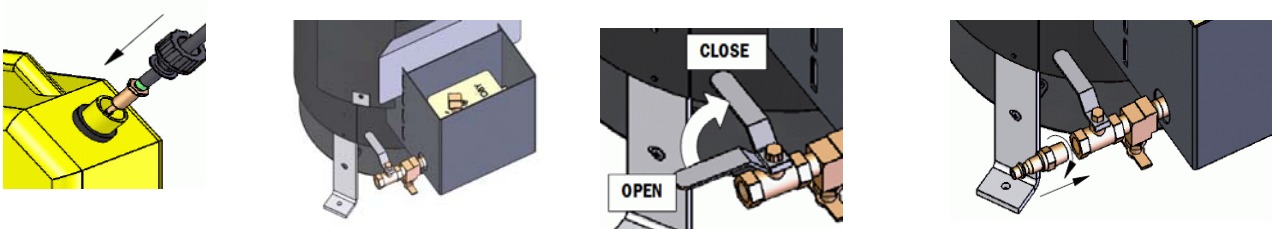

USING A FUEL LINE KIT Place the fuel line filter with attached hose into the fuel of the fuel tank. Remove the brass nipple from the kit and apply sealant to the threads. Screw into the ball valve fitting of the heater and tighten until leak free. Do not over tighten or the threads will be damaged and leakage may occur. Connect the fuel line to the heater using the female quick connect fitting. Turn the heater ball valve lever to the OPEN position and open the fuel drain valve. Squeeze the primer bulb until fuel flows in a steady stream from the drain valve. Catch the fuel in a separate container, then close the fuel drain valve. The fuel line is clear of air.

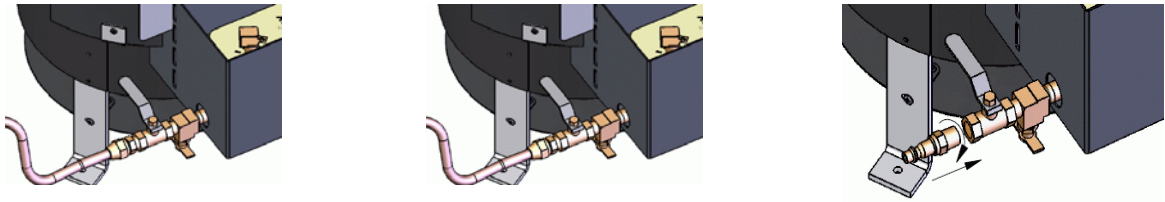

USING A SOLID FUEL LINE Connect the solid fuel line to the heater. Turn the ball valve lever to the OPEN position and open the fuel drain valve. Start the fuel flowing from the fuel tank and wait until fuel flows in a steady stream from the drain valve. Catch the fuel in a separate container, then close the fuel drain valve. The fuel line is clear of air.

When the fuel tank is installed outdoors in very cold temperatures, it is preferable to use #1 diesel fuel and a 3/4" fuel line to avoid any viscosity problems.

The fuel line can be connected to the oil control valve using a 1/4" NPT male fitting.

INSTALLATION OF THE HEATER, FLUE STACK AND FUEL TANK MUST BE INSTALLED IN ACCORDANCE WITH THE REGULATION OF AUTHORITIES HAVING JURISDICTION, NFPA #31, CSA STANDARD B139. AND UL896.

5. Operation

The *Trekker* requires a break-in period between 1 and 2 hours. During this period, some smoke and fumes may be generated from the outside burner case; make sure there is enough ventilation for the smoke and fumes to escape the living or operating areas.

A.) Starting the *Trekker* Heater

To start the *Trekker* Heater:

DO NOT USE ANY UNAUTHORIZED FUELS OR MIX DIFFERENT FUELS. ONLY CLEAN UNCONTAMINATED DIESEL #1, #2 FUEL IS TO BE USED. USING ANY OTHER FUELS COULD CAUSE A FIRE AND/OR EXPLOSION. DO NOT USE GASOLINE, CRANKCASE OIL, OR ANY OIL CONTAINING GASOLINE

- Check for any leaks in the fuel system. Locate and repair any leaks and/or clean any spills before igniting the heater.
- Check the exhaust flue stack for any blockage or anything that might obstruct the exhaust gases. The flue stack must be vented outdoors. Do not let any exhaust gas flow into any living or operating areas.

- Check the exhaust flue stack and the attachment point to the heater for any leaks. Correct any problems before igniting the heater.
- Check the airway around the base of the heater to ensure that the heater receives a clear, unobstructed supply of combustion air.
- Open the fuel shut-off valve from the fuel tank.
- Lift up on Toby Valve Actuating Lever fully and release to let fuel run into the float bowl of the valve.
- Open the glass lid on top of the heater.
- Place the primer cup below the fuel drain valve located beside the Toby valve. Open the drain valve and allow the fuel to drain into the primer cup. Close the drain valve once the cup is full.
- Suck the fuel into the primer bulb by squeezing the rubber bulb and then placing the steel tube into a cup with fuel. When the rubber bulb is released it will suck fuel into the dispenser. The fuel should then be directed toward the **Trekker** burner base by inserting the steel tube through the top lid and squeezing the rubber bulb to expel the fuel. Maximum 1 squeeze with the bulb is enough to start-up the heater.
- When the burner is being lit, it is usually desirable to use a match and a small piece of tissue paper for lighting. Place the Tissue paper in the lid opening. Light the paper and use the auger to drop the tissue down into the base of the burner.
- Securely replace the top lid.
- Place the control knob on the Toby control valve to the first raised "I" mark setting (LOW) next to the "O" mark.
- Wait ten to fifteen minutes for flames to settle down and turn blue before turning the control knob on the Toby control valve counter clockwise to your desired setting.
- If the flame dies out, wait for the heater to cool down to room temperature before repeating the starting procedures.

DO NOT ATTEMPT TO START OR RE-IGNITE THE BURNER WHEN THE BURNER IS HOT.

Do not leave a heater running unattended. ITR accepts no responsibility for any damages caused by leaving the heater running unattended.

B.) Turning off the **Trekker** Heater

To turn off the **Trekker** Heater:

- Turn the control knob on the TOBY Oil Valve to the OFF position marked "O".

- Turn off the Fuel Shut off Valve from the fuel tank to the heater.
- The flame will die out in about five minutes.

ALWAYS KEEP THE OIL VALVE TURNED OFF WHEN THE HEATER IS NOT OPERATING.

6. Oil Control Valve

A.) TOBY Oil Valve

The TOBY Oil Valve is a continuous flow level control valve designed for controlling fuel flow to the **Trekker** heater.

TOBY Oil valves are factory preset to work with your heater. Do not tamper with it. If you have questions or concerns, please contact your authorized **Trekker** Dealer.

The key parts to operating a TOBY Valve for the **Trekker** are the Control knob and the Actuating Lever. The control knob controls the fuel flow rate and can be rotated counter clockwise from the off position, which is the "0" marked on the lid to the high fire position, which is the last raised "I" mark on the lid. The Toby Valve Actuating Lever allows fuel to run into the float bowl of the valve when it is placed in an up position.

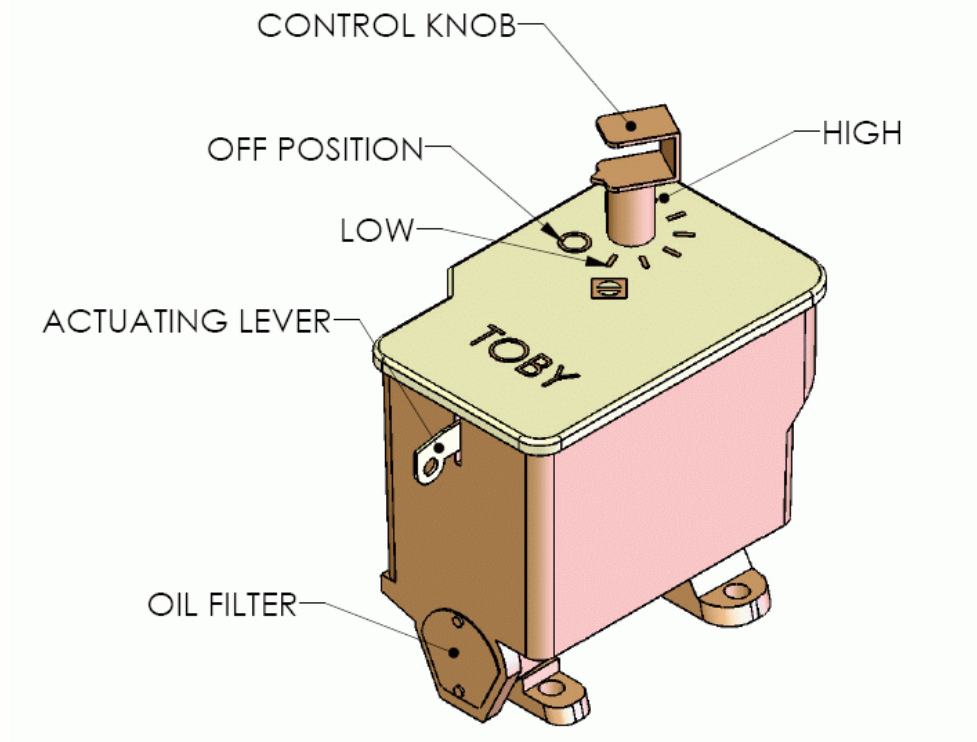

The TOBY Oil Valve has two safety features incorporated into the design of the valve.

- High temperature fuel cut off system. If the temperature of the fuel exceeds 100 degrees Celsius (212 degrees Fahrenheit), fuel will be shut off at the outlet of the valve. Once this occurs, the valve is no longer useable and a new valve is required for the heater to operate.
- Tilt levelling switch. The Toby Oil valve will shut off at the outlet of the valve when the angle of the valve exceeds the following: lengthwise 5 degrees, width wise 15 degrees.

Toby Valves are ULC and DIN approved. The Toby valve requires no maintenance and has no user serviceable parts.

Maintenance

A.) Regular Maintenance

To ensure that your *Trekker* heater operates properly

- every 750 hours of operation or;
- if the output of the heater appears to be have decreased from the same valve setting or;
- if the exhaust exhibits smoke

perform the following maintenance:

- In normal operation, carbon and soot will accumulate in the area of the burner base, up-tube or underneath the high fire ring. These deposits must be periodically removed.
- Working on a cold burner, ensure that the fuel control valve on the heater and the fuel supply to the heater has been turned off. Remove the burner lid and see if there is any soot around or on the perforated burner shell or high fire ring. If so, brush off and vacuum clean.
- Inspect the center up-tube with the supplied metal auger for any obstructions. If there is any obstruction follow the next procedure to loosen and remove any carbon build up in the center up-tube itself.
 - Locate the clean-out plug at the bottom of the burner shell assembly. Place a small catch pan below the opening of the clean-out threaded plug.
 - Use a 9/16 Wrench and remove the threaded hex plug from the bottom of the assembly. Any quantity of fuel still present

in the fuel line will drain into the catch pan. Carefully insert the supplied metal cleaning auger into the up-tube and loosen any hard carbon deposits within the tube by using an up/down twisting motion of the auger. This will loosen any deposits and allow them to fall through the opening of the threaded plug. **Do not use a side to side motion or excessive force or you will distort, bend, or break the welded up-tube.** Continue until the tube is clear of any accumulated deposits.

- o Replace the clean-out plug into the bottom of the burner shell assembly and re-tighten. A high temperature pipe sealant or other appropriate sealing compound should be applied to the threads. Check this threaded plug fitting for any leaks when the heater fuel flow is again re-started. Re-tighten if necessary.

Additional regular maintenance items include:

- 1 Check for any leaks in the fuel system, or suspect areas where a leak might occur and correct.
- 2 Check the flue stack for any damage or areas that might allow flue gases to leak into your heating area and correct.
- 3 Check the flue stack for any blockages and/or soot and remove and correct
- 4 Check for fuel strainer blockage and replace if necessary
- 5 The Toby valve requires no maintenance and has no user adjustable parts

B.) Storing the Heater

On storing the heater for an extended period:

- 6 Perform the previous maintenance steps
- 7 Clean the heater with a rag and spray or wipe with a light mist of oil inside the burner area and outside to prevent rusting.
- 8 Drain all fuel lines and any fuel from the heater

ATTENTION: Regular maintenance is required for the *Trekker* heater to perform as designed. Failure to maintain the heater as required will not only void your warranty but can cause the heater to operate unsafely.

8. Trouble Shooting

A.) Symptom: Burner does not keep lit, flame shuts off.

Recommendations: On a cold heater

- Check for Fuel Shut off Valve in the ON position.
- Check the Control Actuator lever on the Toby Valve and ensure it is at the on position by lifting it up. (This lever does not stay up however)
- Check the Control Knob on Toby Valve is not set to "0" or OFF position.
- Check for incorrect or poor quality fuel.
- Check for blockages in fuel inlet. (i.e. fuel strainer plugged and/or fuel line to heater obstructed)
- Check for blockages in air inlet or exhaust outlet (flue stack).
- There may be air bubbles in fuel line. Give line a quick shake to dislodge bubbles.
- Check for soot or carbon deposit that may have built up inside the up-tube, under the high fire ring, or on the perforated burner shell.

B.) Symptom: Heater does not provide adequate heat and flame appears weak.

Recommendation: On a cold heater

- Check for incorrect or poor quality fuel.
- Check for adequate fuel supply. Ensure the fuel supply valve is open.
- Check fuel line or fuel strainer for blockage of fuel and correct as necessary.
- Check sections of exhaust stack assembly for leakage or blockage and correct as necessary.
- Check intake opening at bottom of heater for free airflow.
- Heavy winds or other weather conditions can increase the draft of the heater. Ensure you have a draft regulator installed and it is connected properly.
- Check for soot or carbon deposit build up inside up-tube, under high fire ring, or on perforated burner shell.
- Check S-tube for proper seating on up-tube. Wait 30 minutes for heater to cool down to room temperature before checking internal tubes.

C.) Symptom: Heater rumbles and or flame appears high on top.

Recommendations:

- Set the Toby valve to a lower setting.
- Check for incorrect or poor quality fuel.
- Check bottom of heater for free airflow.
- Insufficient exhaust stack height could lower the draft of the heater; ensure you have the recommended draft or consult with your authorized Pioneer dealer for the need of a longer flue stack height.

Note: If *Trekker* heater is still not functional, contact your authorized *Trekker* dealer or ITR.

ITR IN CANADA:

2431 Simpson Road

Richmond, BC, Canada V6X 2R2

Tel: 1-800-755-1272 or 604-278-1272

ITR IN THE UNITED STATES:

11915 NE 56th Circle, Suite B

Vancouver, WA USA 98682

Tel: 1-800-993-4402 or 360-993-4877